



Jurnal Terapan Manajemen dan Bisnis is licensed under  
A Creative Commons Attribution-NonCommercial 4.0 International License.

## **The Effect of Organizational Culture, Leader Behavior, Self-Efficacy, and Job Satisfaction on Job Performance of The Employees**

**A. Hussein Fattah<sup>1)</sup>**

<sup>1)</sup> University of Muhammadiyah Palembang, South Sumatera, Indonesia.  
Email: hussein.fattah@gmail.com

### **Abstract**

The objective of this research is to determine the effect of organizational culture, leader behaviour, self-efficacy, and job satisfaction on the job performance of the employees of the Department of Education, Youth and Sport in Palembang city. The sample size was 120 employee and selected by random sampling techniques. The data were analyzed by path-analysis. The findings of the research show that leader behaviour, self-efficacy, and job satisfaction have the direct effect on job performance. Meanwhile, organizational culture has no direct effect on the job performance of the employees of the Department Education, Youth, and Sport in Palembang City.

**Keywords:** job satisfaction, job performance, leader behaviour, organizational culture, self-efficacy

### **Introduction**

This A variety of resources, like humans, materials, machines, are needed to run organization activities. Human resources in an organization employed and in government agencies the employee. Their maximum performance, talent, energy, and creativity are needed by the organization to achieve its goals.

The organization is a place to meet human needs and vice versa human need is the object of organization activities. The government in a country is the biggest organization established by humans. The functions of government are (1) to service all society to meet their individual needs; (2) to handle development aimed at improving people's welfare. To run the functions, government establish smaller organizations: departments, offices, Technical Implementation Unit (UPTD).

Undang-Undang Number 32, 2004 says that local governments are expected to manage their own governmental affairs according to the principle of autonomy and assistance duty. The government of Palembang city is the local government that works based on the principles of autonomy and decentralization. These principles are applied through a democratic process that places the society as a vital subject in development.

The management of the local government affairs in Palembang is based on the authority granted to the city. However, the national government affairs are managed by the national government. The local government carries out the widest possible autonomy to organize and manage its own governmental affairs based on the basis of autonomy and assistance principles. The jurisdiction of local government is based on the following criteria: (1) compulsory and optional affairs, (2) the implementation of mandatory government affairs under the minimum service standards shall be implemented gradually and assigned by the government.

The obligatory affairs of which are the authority of the local government of Palembang city include: (1) development planning and control; (2) spatial planning, utilization, and supervision; (3) management of public order; (4) the provision of public facilities and infrastructure; (5) health care; (6) provision of education; (7) prevention of social problems; (8) service of labor affairs; (9) environmental control; (10) land services; (11) population services, and civil records; (12) public administration services; (13) investment administration services; (14) provision of other basic services; and (15) other mandatory affairs mandated by legislation.

Furthermore, the affairs of South Sumatra province government include real and potential government affairs to improve the social welfare in accordance with the conditions, uniqueness and potential of the region. Local government affairs that are optional require vision based on carefulness, accuracy, and responsibility based the priority scale of development planning and sensitivity to see the problems in line with the dynamics of Palembang society.

From the local regulation of Palembang City Number 3 Year 2001 about Formation, Position, Duty, Principal, Function and Organizational Structure of Regional Technical Institution, Civil Servant (PNS) who works in the environment Palembang government is divided into three major groups of work units, namely Regional Secretariat, Department, and Agency and Office of Palembang.

The establishment of an organization of Department of Education, Youth, and Sport in Palembang is based on Local Government Regulation of Palembang Number 9 The year 2008, August 20, 2008. Education Department in Palembang has the position as executor element of Regional Government in education, youth, and sport. In carrying out the duties, the local government is responsible to the Mayor through the Regional Secretary.

Department of Education, Youth and Sport is a subsystem of the national education system and therefore needs to be developed to participate in the development of national culture.

Performance basically can be seen from two aspects: job performance (individual) and organization performance. Job performance is the performance of an individual in an organization. The organization performance is the totality of work achieved by an organization. Staff performance and organization performance have a very close relationship. The organization goals can not be achieved without the human resources that play an active role to achieve the organization's goals. The maximum performance can not be separated from the organizational culture, staff's self-efficacy and the role of bureaucratic leadership, which in synergy will give job satisfaction for the employees.

Since the Reformation era until now, the performance of government employees has become the public spotlight. This is caused by the dissatisfaction with public service. The results of the Media Group panel discussion highlighted the increasingly worrisome public services (Harian Media Indonesia, 2009). Public service is constantly sued for quality in this

country. Until now, public satisfaction with various public services is still very low, even at minus level.

From the statements above, it can be seen that job performance is very crucial. Therefore, it is important to conduct a deep scientific research about the influence of organizational culture, leader behaviour, self-efficacy, and job satisfaction on the performance of employee at the Department of Education, Youth and Sport in Palembang City.

The problems in this research can be formulated as follows:

1. Are there any effects of organizational culture on job satisfaction?
2. Are there any effects of leader behaviour on job satisfaction?
3. Are there any effects of self-efficacy on job satisfaction?
4. Are there any organizational culture effects on performance?
5. Are there any effects of self-efficacy on performance?
6. Are there any effects of job satisfaction on performance?

**RESEARCH METHOD**

This research was carried out in the Department of Education of Palembang, South Sumatera in September 2015-February 2016. The field test was conducted in August 2015. The subject of this research is the employees of Department of Education, Youth and Sport of Palembang City.

The research method used is survey method, which is done by asking a series of questionnaires to get and formulate the respondent's answer to the question on a value system that is believed to be relative and stable.

The data are analyzed using the causal model with path analysis, that is to test the model and to know the influence of the variables according to the causal model that formed. The variables studied in this research are (1) organizational culture, (2) leader behaviour, (3) self-efficacy, (4) job satisfaction, and (5) performance. The constellations of influence among these variables are described as follows:

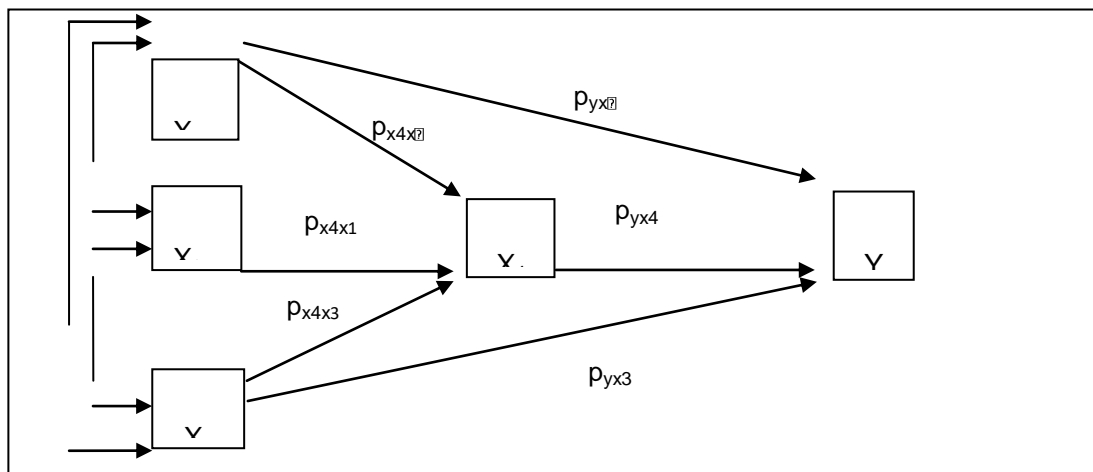

Figure 1. Path Constellation Model among Variables

Description:

X<sub>1</sub> = Organizational culture

X<sub>2</sub> = Leader Behavior

X<sub>3</sub> = Self-Efficacy

X<sub>4</sub> = Job Satisfaction

Y = Staff Performance

p= Path Coefficient

The target population in this study is employees (787 people) under the Department of Education, Youth and Sport in Palembang and the accessible population is all employees (199 people) at the Department of Education, Youth and Sport who serve as a sample frame.

The population have similar characteristics, namely: minimal formal education background is senior high school or vocational senior high school, a minimum level of position/minimum class salary is II/c. The field test was conducted by 30 respondents randomly taken from the population. The sample of this study is 120 people chosen using a simple random sampling technique.

Data obtained were analyzed using descriptive statistical analysis technique, with the inferential statistic, and test requirement analysis. The descriptive statistical analysis is used to describe each variable in a single way: presentation of data in the form of frequency distribution, histogram, central tendency (mean, median, and mode) and variability (range, standard deviation, and variance) of data. The inferential statistical analysis is used to test the research hypothesis by using path analysis.

## RESULTS AND DISCUSSIONS

### Results

Table 1. Data Description

Variabel	Mean	Standard Deviation	Variance	Median	Mode
<b>Performance</b>	149,80	17,44	304,21	150,00	133,00
<b>Organizational culture</b>	137,00	12,24	149,80	136,00	136,00
<b>Leader Behavior</b>	153,43	16,59	275,27	153,50	171,00
<b>Self-efficacy</b>	131,80	10,83	117,18	130,50	141,00
<b>Job Satisfaction</b>	134,50	13,22	174,74	135,00	136,00

Some conditions for analysis must be fulfilled for further analysis, both for predicting purposes and for hypothesis testing purposes. There are two conditions that must be met before performing the path analysis ie normality test and linearity test. The research results can be seen in the following diagram.

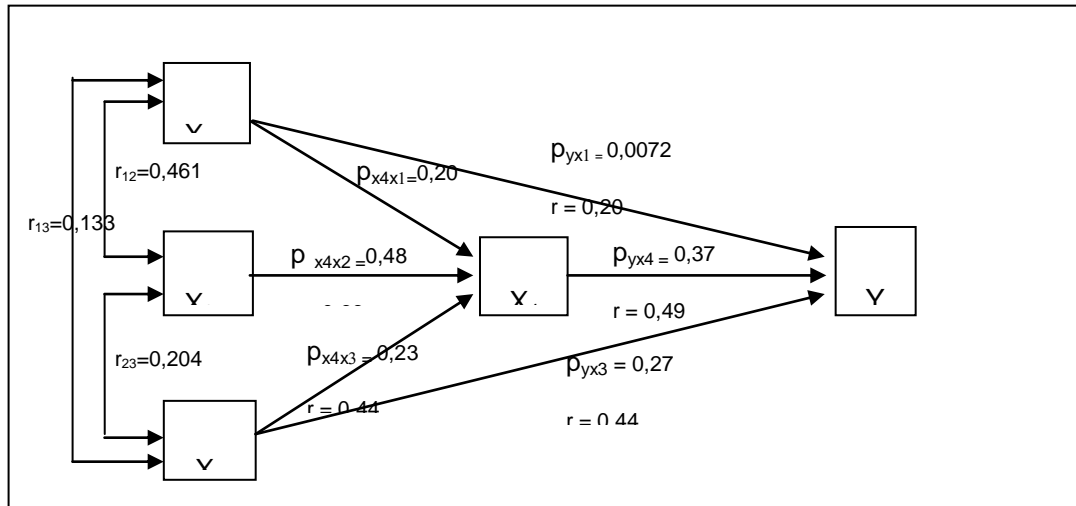

Figure 2. Path diagram organizational culture (X<sub>1</sub>), leader behaviour (X<sub>2</sub>), self-efficacy (X<sub>3</sub>) and job satisfaction (X<sub>4</sub>) against performance (Y)

### Hypothesis Testing

The results of hypothesis testing of this study are summarized in the following table.

**Table 2**  
**Recapitulation of Hypothesis Testing Results**

No.	Hypothesis	Test Statistics	Decision	Conclusion
1	Organizational culture (X <sub>1</sub> ) has direct effect on Job satisfaction (X <sub>4</sub> )	H <sub>0</sub> : $\beta_{yx_1} \leq 0$ H <sub>1</sub> : $\beta_{yx_1} > 0$	H <sub>0</sub> Rejected H <sub>1</sub> Not Rejected	Have Direct Effect
2	Leader Behavior (X <sub>2</sub> ) has direct effect on job satisfaction (X <sub>4</sub> )	H <sub>0</sub> : $\beta_{x_4x_2} \leq 0$ H <sub>1</sub> : $\beta_{x_4x_2} > 0$	H <sub>0</sub> Rejected H <sub>1</sub> Not Rejected	Have Direct Effect
3	Self Efficacy (X <sub>3</sub> ) has direct effect on job satisfaction (X <sub>4</sub> )	H <sub>0</sub> : $\beta_{yx_1} \leq 0$ H <sub>1</sub> : $\beta_{yx_1} > 0$	H <sub>0</sub> Rejected H <sub>1</sub> Not Rejected	Have Direct Effect
4	Organizational culture (X <sub>1</sub> ) has direct effect on performance (Y)	H <sub>0</sub> : $\beta_{yx_1} \leq 0$ H <sub>1</sub> : $\beta_{yx_1} > 0$	H <sub>0</sub> Rejected H <sub>1</sub> Not Rejected	Have Indirect Effect
5	Self Efficacy (X <sub>3</sub> ) has direct effect on performance (Y)	H <sub>0</sub> : $\beta_{yx_3} \leq 0$ H <sub>1</sub> : $\beta_{yx_3} > 0$	H <sub>0</sub> Rejected H <sub>1</sub> Not Rejected	Have Direct Effect
6	Job Satisfaction (X <sub>4</sub> ) has direct effect on performance (Y)	H <sub>0</sub> : $\beta_{yx_4} \leq 0$ H <sub>1</sub> : $\beta_{yx_4} > 0$	H <sub>0</sub> Rejected H <sub>1</sub> Not Rejected	Have Direct Effect

### Discussions

#### 1. The Effect of Organizational Culture (X<sub>1</sub>) on Job Satisfaction (X<sub>4</sub>)

The results of this study indicate that there is a direct positive effect of organizational culture (X<sub>1</sub>) to job satisfaction (X<sub>4</sub>). This is supported by the theory that states that organizational culture is the archetype of values and assumptions in organizations that directly affect the people in the organization to do what is right (McShane & von Glinow, 2008). In addition, another theory states that organizational culture is a system of shared

values, is often taken for granted, which helps people in the organization understand which acceptable and unacceptable actions (Griffin & Moorhead, 2007). These values are communicated through stories and symbolic means. Organizational culture is what employees perceive and how it creates a pattern of beliefs, values, and expectations (Ivancevich et al., 2008). Organizational culture is a collection of traditions, values, policies, beliefs, and behaviours that are generally applicable to any committed and considered members of the organization (Mullins, 2005).

The findings in this study are in line with the theory that the organizational culture within the Department of Education, Youth and Sport in Palembang leads to job satisfaction.

### 2. The Effect of Leader Behavior (X<sub>2</sub>) on Job Satisfaction (X<sub>4</sub>)

The results of this study indicate that there is a direct positive effect on leader behaviour (X<sub>2</sub>) on job satisfaction (X<sub>4</sub>). This is supported by the theory that states that the path-goal leadership model is used to select leadership styles (directive, supportive, participatory, or achievement-oriented) that are appropriate to the situation (employees and environment) to maximize performance and job satisfaction (Achua & Lussier, 2010) (illustrated as shown below).

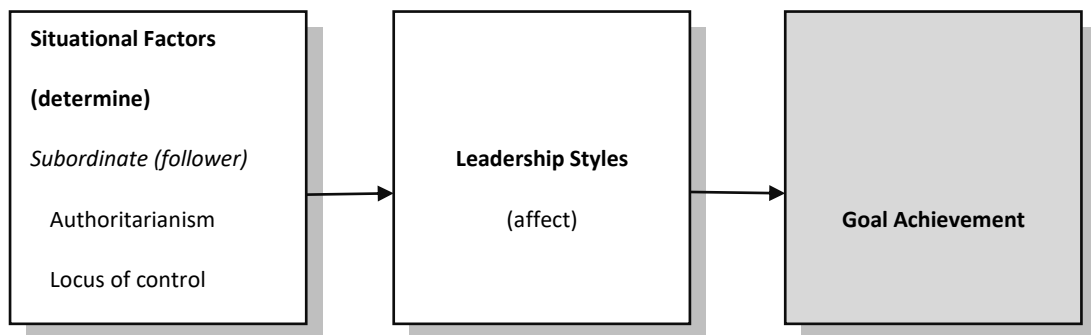

Figure 3. House path-goal leadership model

The results of this study are in accordance with the theory of path-goal leadership model. This fact also applies to the environment of the Department of Education, Youth, and Sport in Palembang, that the leader behaviour has the effect on employee job satisfaction.

### 3. The Effect of Self-Efficacy (X<sub>3</sub>) on Job Satisfaction (X<sub>4</sub>)

The results of this study indicate that there is a direct positive effect of self-efficacy (X<sub>3</sub>) on job satisfaction (X<sub>4</sub>). This is supported by the theory that states that self-efficacy is a person's beliefs about their ability to organize and implement necessary actions to achieve goals (Bandura, 1977). In other words, people who have strong efficacy own more confident about their capacity to carry out a behaviour. Confidence about self-efficacy has a significant effect on goals and achievements by influencing personal choice, motivation, and emotional patterns and reactions. For example, a person tends to avoid situations that threaten him or her and believe to have more ability to overcome them. Self-efficacy is also perceived to give effects on how people achieve goals by influence their effort in facing obstacles. This means the stronger self-efficacy is perceived, the more active the effort is. High self-efficacy is also associated with more persistent which allows one to have corrective experience that strengthens the assurance of self-efficacy. So, one will be satisfied with a job when the job is completed.

In line with the results of the research and the theory that supports, It can be stated that self-efficacy in the Department of Education, Youth and Sport in Palembang encourages job satisfaction.

**4. The Effect of Organizational Culture (X<sub>1</sub>) on Performance (Y)**

The findings of the research show that there is no direct effect of organizational culture (X<sub>1</sub>) on performance (Y). Organizational culture is an invisible force but can affect the thoughts, feelings, actions and performance of people who work in an organization. *“Organizational culture consists of the values and assumptions shared within an organization. It defines what is important and unimportant in the company and consequently directs everyone in the organization toward the right way of doing thing”*(McShane & Von Glinow, 2008)

The findings are different from the theory, the case in Department of Education, Youth and Sport in Palembang shows that organizational culture has no direct effect on job performance.

**5. The Effect of Self-Efficacy (X<sub>3</sub>) on Performance (Y)**

The findings of this research results indicate that self-efficacy (X<sub>3</sub>) has a direct positive effect on performance (Y). This is supported by the theory that self-efficacy is as a person's beliefs about their ability to organize and implement necessary actions to achieve goals(Bandura, 1977). Thus, it can be stated that self-efficacy of employees in the Department of Education, Youth and Sport in Palembang can encourage employees to perform well.

**6. The Effect of Job Satisfaction (X<sub>4</sub>) on Performance (Y)**

The findings of this research results indicate that job satisfaction (X<sub>4</sub>) has a direct positive effect on performance (Y). The findings of this study are similar to the that states that in general, the relationship between job satisfaction and job performance are as follows: (1) job satisfaction has effect on job performance; (2) job performance has effect on job satisfaction; (3) there is moderate variable, appreciation, in relationship of job satisfaction. The picture below shows the three points of view(Ivancevich et al., 2008)

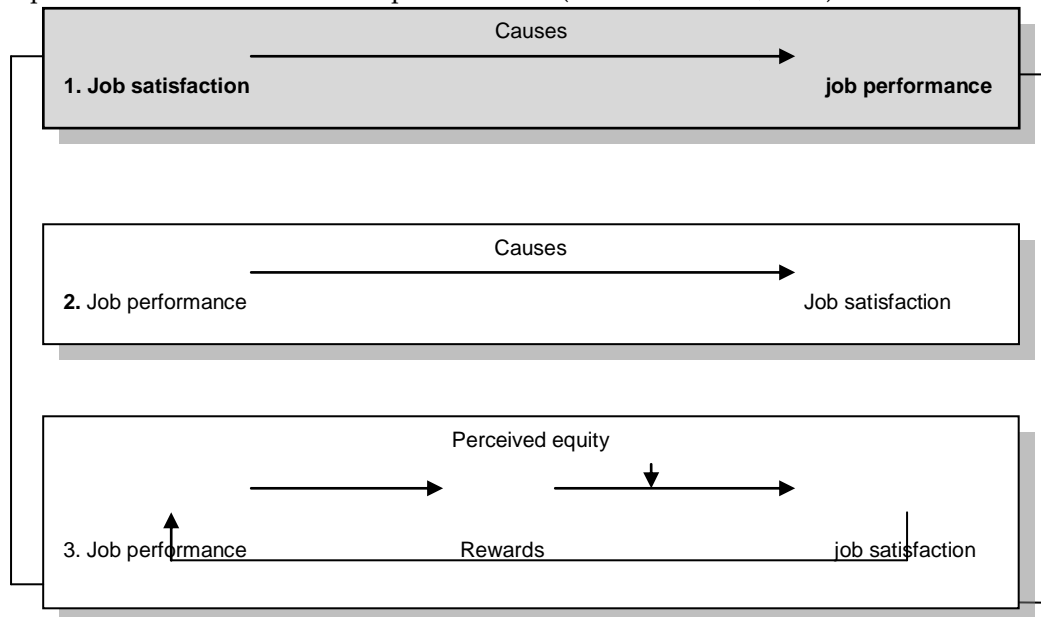

Figure 4. Satisfaction-performance relationships: Three views



**The results of this research are in accordance with the theory that job satisfaction of employees in the environment the Department of Education, Youth and Sports in Palembang causes a high-performance.**

### Conclusion

From the results and discussion of this research, it can be concluded as follows.

1. Organizational culture has a direct positive effect on job satisfaction. This means high organizational culture leads to an increase of the employees of job satisfaction in the Department of Education, Youth, and Sport of Palembang City.
2. Leader behaviour has a positive direct effect on job satisfaction. This means, in the Department of Education, Youth and Sport of Palembang City, the better the leader's behaviour is, the higher the employees of job satisfaction.
3. Self-efficacy has a direct positive effect on job satisfaction. This means high self-efficacy leads to an increase of the employees of job satisfaction in the Department of Education Youth, and Sport of Palembang City.
4. Organizational culture has no direct effect on performance. This means high organizational culture does not directly affect the performance of the employees of the Department of Education, Youth, and Sport of Palembang City.
5. Self-efficacy has a direct positive effect on performance. This means high self-efficacy leads to an increase of job performance in the Department of Education, Youth, and Sports of Palembang City.
6. Job satisfaction has a direct positive effect on performance. This means, performance in the Department of Education, Youth, and Sports of Palembang City, the higher the job satisfaction is, the higher the job performance is.

### REFERENCES

- Achua, C. F., & Lussier., R. N. (2010). *Effective Leadership, Fourth Edition*. Ohio: South-Western Cengage Learning.
- Bandura, A. (1977). Self-Efficacy: Toward A Unifying Theory Of Behavioral Change. *Psychological Review*, 84(2). Accessed on September 11, 2015 from <http://www.des.emory.edu/mfp/eff.html>.
- Carol, T., & Keasey. (1985). *Child Development: Psychological, Social Cultural, and Biological Factor*. Illinois: The Dorsay Press.
- Cascio, W. F., & Aguinis, H. (2005). *Applied Psychology in Human Resource Management, Sixth Edition*. New Jersey: Pearson Education, Inc.
- Chatman, J. A., & Jehn, K. A. (1994). Assesing the Relationship Between Industry Characteristics and Organizational Culture: How Different Can You Be?". *Academy of Management Journal*.
- Colquitt, J. A., Lepine, J. A., & Wesson, M. J. (2009). *Organizational Behavior Improving Performance and Commitment in the Workplace*. New York: Mcgraw Hill Company.
- Daft, R. L. (2005). *Management, Sixth Edition*. Ohio: Thomson South Western.
- Gibson, J. L., Ivancevich, J. M., & Donnelly, J. H. (1997). *Organizations: Behavior, Structure, Processess*. Chicago: Richard D. Irwin.
- Griffin, R. W., & Moorhead, G. (2007). *Organizational Behavior, Managing People and Organizations*. New York: Houghton Mifflin Company.
- Harian Media Indonesia. (2009). Layanan Publik Yang Kian Mencemaskan. *Media Indonesia*.
- Hughes, R. L. (2009). *Leadership, Enhancing The Lesson of Experience, Sixth Edition*. New York:



- Mcgraw-Hill Education Companies Inc.
- Ivancevich, J. M., Konopaske, R., & Matteson, M. T. (2008). *Organizational Behavior And Management*. New York: Mcgraw Hill Company Inc.
- Jex, S. M. (2002). *A Scientist-Practitioner Approach, Organizational Psychology*. New York: John Wiley & Sons Inc.
- Kreitner, R., & Kinicki, A. (2008). *Organizational Behavior, Key Concepts, Skills and Best Practices*. New York: Mcgraw Hill Company Inc.
- Madura, J. (2007). *Introduction to Business 4th Edition*. Usa: Thomson South-Wester.
- Mckenna, E. (2011). *Business Psychology and Organizational Behavior, Third Edition*. New York: Psychology Press.
- Mcshane, S. L., & Von Glinow, M. A. (2008). *Organizational Behavior, Fourth Edition*. New York: Mcgraw Hill Company Inc.
- Mullins, L. J. (2005). *Management and Organizational Behavior Seventh Edition*. England: Pearson Education Limited.
- Newstrom, J. W. (2007). *Organizational Behavior, Human Behavior at Work, Twelfth Edition*. New York: Mcgraw Hill Company Inc.
- Northouse, P. G. (2003). *Leadership, Theory And Practice, Third Edition*. New Delhi: Response Book.
- O'reilly Iii, C. A., Chatrnan, J., & Caldwell, D. F. (1991). People And Organization Culture: A Profile Comparison Approach to Assesing Person-Organization Fit. *Academy of Management Journal*, 34(3), 487–516.
- Ormord, J. E. (2003). *Educational Psychology: Developing Learners, 4th Edition*. New Jersey: Merrill Prentice Hall.
- Pajares, F., & H, S. D. (2001). Self-Beliefs And School Success: Self\_Efficacy, Self-Concept, and Scholl Achievement. In R. Riding & S. Rayner (Eds.), *Perception* (Pp. 239–266). London: Ablex Publishing.
- Robbins, S. P., & Judge, T. A. (2008). *Organizational Behavior, 13th Edition*. Prentice Hall.
- Rucky, A. S. (2006). *Sistem Manajemen Kinerja (Performance Management System)*. Jakarta: Gramedia Pustaka Utama.
- Stajkovic, A. D., & Luthans, F. (1998). Social Cognitive Theory And Self-Efficacy: Going Beyond Traditional Motivation and Behavior Approaches. *Organizational Dynamics*, 26(4), 62–74.
- Supriyanto, T. (2007). *Managing Performance Managing People*. Jakarta: Bhuana Ilmu Populer.