



This work is licensed under

[a Creative Commons Attribution-NonCommercial 4.0 International License.](https://creativecommons.org/licenses/by-nc/4.0/)

Utilizing Flat Coil-Based Vibration Sensor on A Bamboo Drum as Disaster Preparedness Media For Students

Islahudin ^{1*}, Haifaturrahmah ², Muhammad Nizaar ³, Soeharto ⁴

Universitas Muhammadiyah Mataram, Indonesia^{1,2,3}, University of Szeged, Hungary⁴

*Corresponding email: islahudin.ntb@gmail.com

Received: December 29th, 2021. Revised: July 12th, 2022. Accepted: August 1st, 2022

Keywords :

Flat Coil; Bamboo Drum;
Disaster

ABSTRACT

People's awareness of earthquakes is very deficient, and their earthquake mitigation is also relatively scant. The research objectives are: 1) Designing a flat coil-based vibration sensor on a Security Post Drums as a Disaster preparedness media for Muhammadiyah Elementary School students; 2) Analyzing how high the level of disaster preparedness for Muhammadiyah Elementary School students through a flat coil-based vibration sensor on the Security Post Drums. This study uses two methods, i.e., 1) The experimental method was used to design the flat coil-based vibration sensor installed on the Security Post Drums. The vibration frequency measured by the flat coil sensor is the low frequency. The Security Post Drums work by striking it once or more, and then the vibration propagates to the sensor so the siren will blare; and 2) Qualitative and quantitative method used to measure students' preparedness in Muhammadiyah Elementary School. The samples applied are 26 students taken by random sampling method. The data on students' preparedness was collected using a questionnaire instrument. The research variable of the preparedness consisted of 5 aspects, i.e., 1) knowledge on types of disasters; 2) steps taken at the beginning of a disaster; 3) steps undertaken right after the disaster occurred; 4) materials need to prepared when disaster struck, and 5) preparedness in dealing disaster. The assessment was carried out using the Likert scale. The results of this research are 1) the disaster preparedness media for Aisyiyah Elementary School students has been designed in a flat coil-based sensor integrated with security post drums); 2) the level of disaster preparedness for Aisyiyah Elementary School students increased. This improvement was indicated that the posttest score (ranges from 60 until 68.18) was more significant than the pretest score (ranges from 49 until 58) on the overall five aspects.

INTRODUCTION

Indonesia is an archipelagic country with enormous earthquake sources, tectonic and volcanic earthquakes. Lombok island is included in the region located in the earthquake pathways. This situation conduces Lombok island hit by an earthquake with a 7,0 Richter Scale on 05 August 2018.

The earthquake that struck Lombok island on 05 August 2018 caused approximately 70% of Lombok areas to wreck. Thousands of houses were heavily damaged, moderately damaged, and minor damaged. As for the casualties, 600 people were killed, thousands of people heavily injured, and minors injured, consisting of various ages such as infants, adolescents, and adults. In 2021, 2,5 years have passed since the earthquake struck Lombok island, West Nusa Tenggara. Hence, it is crucial to be vigilant and alert on the disaster occurrence that can come out anytime [1].

According to the research conducted by Syahrial Ayub [2], people's awareness of earthquakes is very deficient, and their earthquake mitigation is also relatively scant. An earthquake is a natural disaster that cannot be predicted when it occurs: it can strike suddenly and anytime, such as while working, sleeping, playing, and even when children are studying at school. Children are the most vulnerable groups being the earthquake victims, followed by teachers and other school staff. Thus, they need to be equipped with an earthquake concept and disaster concept in general, although there are other catastrophes, i.e., tsunami, landslide, flood, drought, storm, and volcanic eruption disasters. Meanwhile, according to the research conducted by Fika Nur Indriasari [3], it was obtained information that disaster preparedness education can be built since early age through a disaster preparedness education program in the school so that children can know how to save themselves when the disaster occurs. Disaster preparedness education can be started in elementary school education because, according to Piaget, this stage is a concrete operational phase [4] [5]. In addition, disaster preparedness is needed especially for elementary school students who are a vulnerable group when a disaster occurs [6] [7].

The analysis conducted in Syahrial Ayub [2] research derives several weaknesses, such as the analysis of earthquake preparedness disaster on children is limited only to disaster signs without carrying out direct simulation when the data collection in the research was conducted. In addition, the result of disaster research was not followed by providing a media or a tool that can help students in SDN 6 Mataram recognize when an earthquake occurred. As for the analysis conducted by Haryuni [6], it is derived information that the research result of disaster preparedness conducted was not followed by a media or a sensor tool that can help Elementary School students to recognize the signal when an earthquake occurred. The elementary school students' age applied in this research was not explained in detail [8] [9].

Based on several studies above, the research team accounts that it is crucial to conduct research utilizing flat coil vibration sensors as the disaster preparedness media for Muhammadiyah Elementary School students in Lombok Island. The purpose of the flat coil vibration sensors is to detect the earthquake's vibration at any time. Its benefit is measuring the earthquake's vibration frequency in the low frequency. The strength of this research is to analyze disaster preparedness in Muhammadiyah Elementary School students accompanied by a flat coil-based vibration sensor installed in the Security Pos Drums. For this reason, the research team have conducted research entitled "Utilizing a Flat Coil-Based Vibration Sensor on a Bamboo Drum as Disaster Preparedness Media for Muhammadiyah Elementary School students".

METHOD

This research uses two methods, i.e., 1) The experimental method involves manipulating one variable to determine if this causes changes in another variable at the laboratories; and 2) Qualitative and quantitative method [10]. Due to the Covid-19 circumstances, the research was conducted under the high health protocol. The experimental method was used to design the flat coil-based vibration sensor

installed on the Security Post Drums using whereas qualitative and quantitative methods to measure students' preparedness in Muhammadiyah Elementary School. The research population is from grade IV until grade VI students in Muhammadiyah Elementary School. The samples used are 26 students of Aisyiyah 2 Mataram Elementary School. Generally, the research stages include: Designing Element for Flat Coil Sensor, Designing Analog Signal Processor of Flat Coil Sensor, Designing Flat Coil Sensor to the Security Post and Siren, and Measuring the level of students' disaster preparedness in Muhammadiyah Elementary School.

The First Method: Designing the Flat coil sensor on the Security Post Drums and Siren

Steps on the first method are 1) Designing Elements for Flat Coil Sensor, 2) Designing Analog Signal Processor of Flat Coil Sensor, and 3) Designing Flat Coil Sensor to the Security Post and Siren.

1. Designing Element for Flat Coil Sensor

The element of the flat coil sensor was made of PCB, which was arranged in 30 turns with 3cm diameters, and each inductance value is 7,8 μH . The element of flat coil visual appears in Figure 1 [11].

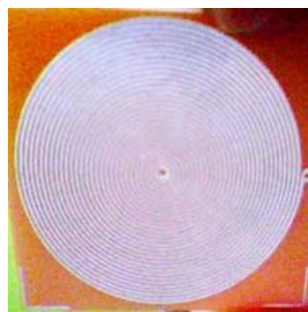

Fig 1. Flat Coil Element

2. Designing Analog Signal Processor of Flat Coil Sensor

The analog signal processing circuit consisted of a sensor signal processor, filter, and differential amplifier. The block diagram of the analog signal processor arrangement can be seen in Figure 2.

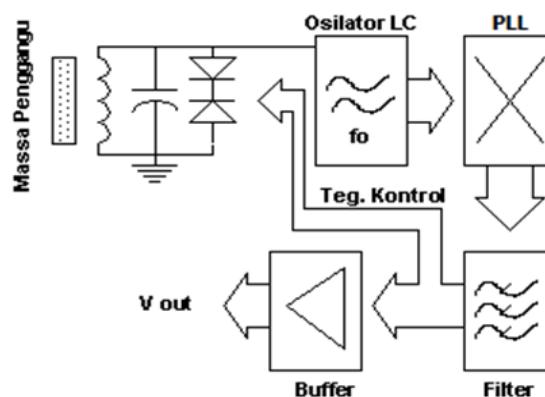

Fig 2. Diagram Block of Analog Signal Processor Arrangement

3. Designing Flat Coil Sensor to the Security Post and Siren

The design of a flat coil vibration sensor in the bamboo drums or Security Post can be seen in Figure 3. The bamboo drums operate with this principle; when the drum is stroke once, it will generate vibration that propagates to the flat coil. Subsequently, the flat coil will transform the vibration as an input signal in which it produces an output voltage (V_{out}) in the sensor. Afterward, the sensor voltage output will become the voltage source to turn the siren continuously sounding as the indicator.

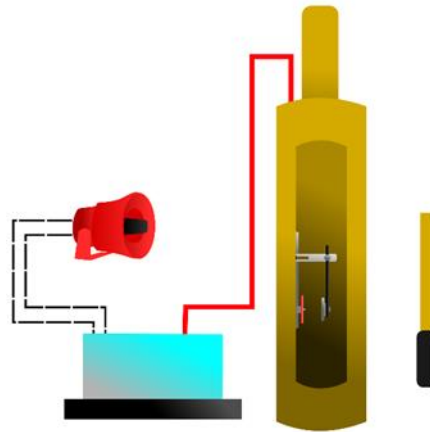

Fig 3. Flat coil sensor on the Security Post Drums and Siren

Therefore, with this indicator of disaster occurrence, it becomes the announcement for children in Muhammadiyah Elementary School to be cautious and aware.

The Second Method: Measuring the level of students' disaster preparedness in Muhammadiyah Elementary School

Steps on the second method are 1) Designing the flow diagram of the research, 2) Designing the instrument to measure the student's preparedness, and 3) Analysis of data on the student's preparedness.

1. Designing the Flow Diagram of the Research

The method used in this research was the pre-experiment method [10], the Pre-experiment research result is a dependent variable not solely affected by the independent variable. This result is due to the existence of a control variable, and the sample was not selected randomly. The research activity covers three stages, e.g., preparation, implementation, and final stages. The research flow diagram can be seen in Figure 4 [12] [13].

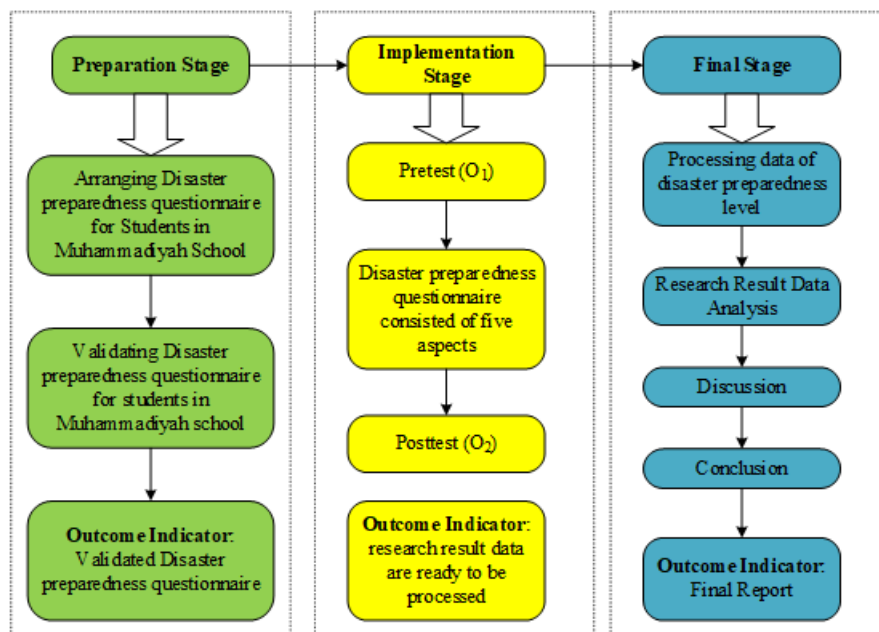

Fig 4. Research Flow Diagram in Measuring Disaster Preparedness Level

Outcome Indicator: Processing data of disaster preparedness level questionnaire consisted of five aspects (O₁) for students in Muhammadiyah Elementary School.

2. *Designing the Instrument to Measure the Student's Preparedness*

The instrument to measure the student's disaster preparedness is the questionnaire which consists of 5 aspects, i.e., 1) knowledge on types of disasters; 2) steps taken at the beginning of a disaster; 3) steps undertaken right after the disaster occurred; 4) materials need to prepared when disaster struck, and 5) preparedness in dealing disaster. As just the sample, the details of the first aspect, that is, knowledge of types of disasters, appear in Table 1.

Table 1. The Details of the First Aspect are Knowledge of Types of Disasters

Knowledge on Types of Disasters
1. Natural disasters often occur in Indonesia, one of which is earthquakes
2. In addition to quakes, tsunamis have also appeared in Indonesia
3. A tsunami is a massive wave on the coast that overflows into residential areas
4. Earthquakes cannot be predicted when they will occur

Based on Table 1, each item has points between 1 and 4 using the Likert scale, where 1: Strongly disagree, 2: Disagree, 3: Agree, and 4: Strongly Agree. The research design applied in this research was *one group pretest-posttest design*. The *one-group pretest-posttest design* is a type of quasi-experiment in which the outcome of interest is measured 2 times: once before and once after exposing a random group of participants to a certain treatment. In this design, prior to giving the treatment, the sample was treated with a pretest (initial test), and in the last activity, they were tested with a posttest (final test).

The questionnaire regarding the student's response to a flat coil-based vibration sensor on a security pos drums consists of 4 aspects that is 1) the objective of the sensor system, 2) detection result presentation, 3) design attractiveness, and 4) safety. As for one aspect, namely the purpose of the sensor system, the details are shown in Table 2.

Table 2. The Details of the Purpose of the Sensor System

Purpose of the Sensor System
1 The flat coil sensor on the Security Post Drums gives information about earthquakes
2 The flat coil sensor on the Security Post Drums is the right tool as an earthquake warning medium
3 The Flat coil sensor on the Security Post Drums is beneficial in preparing earthquake warnings
4 The Flat coil sensor on the Security Post Drums is suitable for elementary school use
5 The Flat coil sensor on the Security Post Drums provides information according to needs
6 This sensor tool can become a supplement learning material in schools.

Based on Table 2, each item has points between 1 and 4 using the Likert scale, where 1: Very Bad, 2: Not Good Enough, 3: Good, and 4: Excellent.

3. *Analysis of Data on the Student's Preparedness*

The data was collected using a questionnaire instrument previously validated by the expert validator before the questionnaire was distributed to the research sample. Before the instrument was implemented in this research, it was previously validated by the expert validator. The assessment was carried out using the *Likert* scale [10] by assessing score ranges from 1 until 5. For grasping the percentage of disaster preparedness, it was applied the following formula:

$$P_n = \frac{\text{Score of Aspect } N}{\text{Aspect } N \text{ Maximum Score}} \quad (1)$$

where P_n is the percentage of Aspect N, while N = 5 because the preparedness aspect measured is five items.

RESULTS AND DISCUSSIONS

The Preparation of a Flat Coil-Based Vibration Sensor

The element of the flat coil sensor was made of PCB, which was arranged in 30 turns with 3cm diameters, and each inductance value is 7,8 μ H. The element of flat coil visual appears in Figure 5.

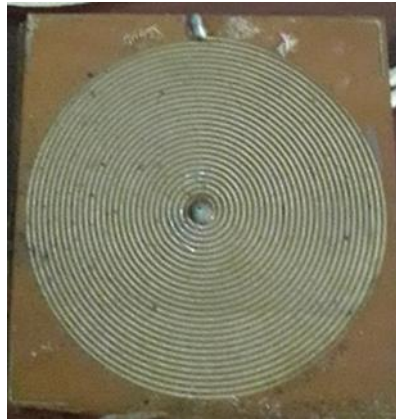

Fig 5. Flat Coil Sensor in the Security Post Drums and Siren

Designing Analog Signal Processor of Flat Coil Sensor

The analog signal processing circuit consisted of a sensor signal processor, filter, and differential amplifier [14] [15]. The block diagram of the analog signal processor arrangement can be seen in Figure 6.

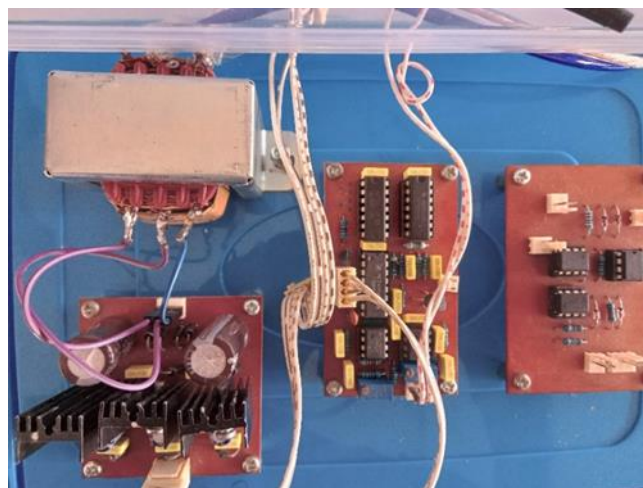

Fig 6. Analog Signal Processor Circuit

Based on Figure 6, it is seen that the circuit series of signal processor arrangement are transformer, power supply circuit, and flat coil sensor circuit.

Design of Flat Coil Sensor in Security Post Drums and Siren

The design of the Flat Coil Sensor in Security Post Drums and Siren can be seen in Figure 7.

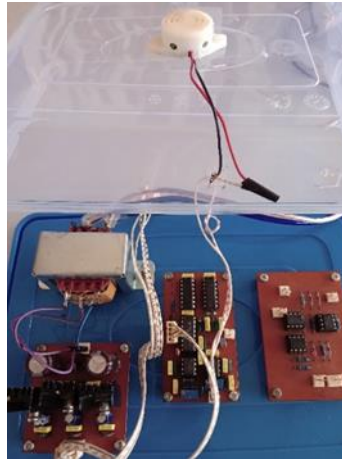

Fig 7. Flat Coil Sensor in the Security Post Drums and Siren

Based on Figure 7, it is observed that the signal processor circuit was connected with a power supply which has output voltage respectively +9 V, -9 V, +5 V, and 0 V., The output voltage of the flat coil signal processing circuit, are 0 – 8 V so that this voltage was used to turning on and turning off the siren or buzzer. The bamboo drums connected with the flat coil sensor and siren are seen in Figure 8.



Fig 8. Design of Flat Coil Sensor and Bamboo Drum is being stroked

Based on Fig 8, when the Drum is struck once, it will generate a vibration source that propagates to the flat coil [16] [17]. Subsequently, the flat coil will transform the vibration into an input signal, producing an output voltage (V_{out}) in the sensor. Afterward, the sensor output voltage will become the voltage source to turn on the siren or buzzer to sound continuously as an indicator. Therefore, this indicator will become the sign for students to be alert immediately. As observed in Figure 8, a student in Aisyiyah 2 Mataram Elementary School is stroking the bamboo drums to turn on the siren or buzzer sound.

The Measurements of Students' Disaster Preparedness.

There are two types of students' responses to the disaster preparedness level of Muhammadiyah Elementary School Students; they are 1) students' responses on flat coil sensor installed to the Security Post Bamboo Drum: the aspect measured are the objective of sensor system, detection result presentation, design attractiveness, and safety. 2) students' responses on disaster preparedness: the aspect measured are knowledge on types of disasters, steps carried out when the disaster occurred, steps carried out after the disaster, materials need to be prepared when the disaster occurred, and preparedness in dealing with disaster [18] [19].

Students' Response on Flat Coil Sensor in the Bamboo Drum

Students respond to the flat coil sensor installed on the bamboo drum, as shown in Figure 9.

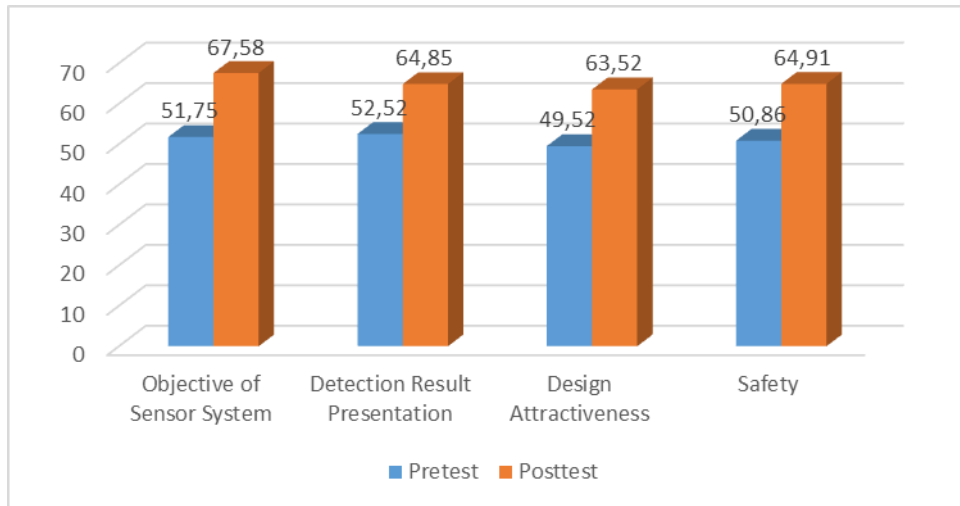

Fig 9. *Students' Response on Flat Coil Sensor in the Bamboo Drum*

Based on Figure 9, it is seen that students' responses are different in the pretest and posttest results regarding the flat coil sensor installed in the Security Post Bamboo drum. The chart shows the posttest score (ranges to 63.52 until 67.58) more significant than the pretest score (ranges to 49.52 until 51.75). The range score of the posttest from 63.52 to 67.58 regarding the students' responses to the Flat Coil Sensor in the Bamboo Drum is in a good category. This result was because, during the pretest, students have not understood how to grasp the security post drum connected to the flat coil. Meanwhile, in the posttest, it has been conducted socialization and trial with students regarding utilizing flat coil sensors in the Security Post bamboo drum so that students' understanding improved [20].

The student responses on Disaster Preparedness

Students' responses to disaster preparedness can be seen in Figure 10.

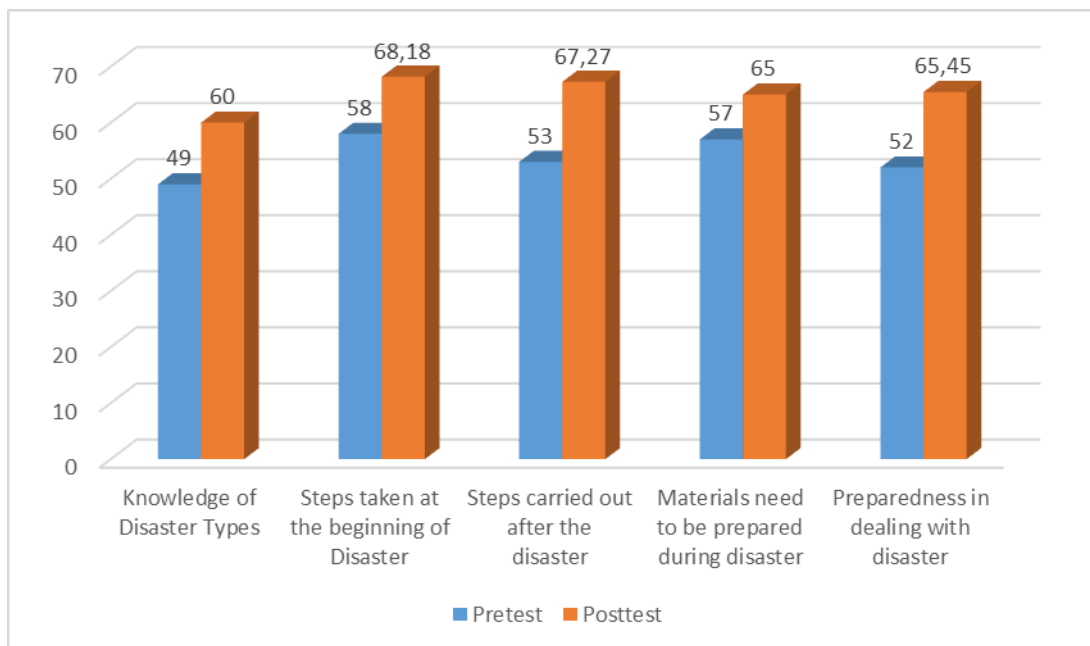

Fig 10. *The student responses on Disaster Preparedness*

Based on Fig 10, it can be seen that students' responses are different on the pretest and posttest regarding disaster preparedness. The chart shows the posttest (ranges to 60 until 68.18) more

significant than the pretest (ranges to 49 until 58) in overall five aspects. This difference indicates students' improvement on the five aspects of disaster preparedness [21]. The range score of the posttest from 60 to 68.18 regarding the students' disaster preparedness is in the category of good. The aspect of steps taken at the beginning of a disaster has the highest score, 68.18. The details on steps taken at the beginning of a disaster consist of 5 things: 1) when an earthquake occurs, we must stay away from buildings and trees, 2) when an earthquake occurs, we should not use the elevator, 3) when indoors, we must take shelter under a strong table, 4) protect the head with safe objects such as books, bags and pillows, and 5) when a disaster occurs, we should not panic and follow adults' directions.

This improvement was because the students were provided with socialization regarding disaster preparedness to use the flat coil sensor-based Security Post bamboo drum as the media. The result indicates that disaster preparedness education can be built since early age through a disaster preparedness education program in the school [4] [5]. In other words, there was an effect of disaster preparedness education on students' knowledge about earthquake disaster preparedness. The disaster education dissemination must always be improved and make it a core curriculum in learning material and routinely conduct training or simulations between elementary school's environment and related agencies that handle the earthquake disaster [22]. The student's response when hitting or sounding the electric bamboo drum is so good because it is a unique tool directly connected to the siren.

CONCLUSION AND SUGGESTION

Conclusion

Based on the results of this research, it can be deduced that 1) the disaster preparedness media for Aisyiyah Elementary School students has been designed in a flat coil-based sensor integrated with security post drums); 2) the level of disaster preparedness for Aisyiyah Elementary School students increased. The range score of the posttest from 60 to 68.18 regarding the students' disaster preparedness is in the category of good. The aspect of steps taken at the beginning of a disaster has the highest score, 68.18. The details on steps taken at the beginning of a disaster consist of 5 things: 1) when an earthquake occurs, we must stay away from buildings and trees, 2) when an earthquake occurs, we should not use the elevator, 3) when indoors, we must take shelter under a strong table, 4) protect the head with safe objects such as books, bags and pillows, and 5) when a disaster occurs, we should not panic and follow adults' directions.

Suggestion

The suggestion provided is that it needs follow-up research regarding the level of disaster preparedness for students in Aisyiyah/Muhammadiyah Elementary School other than earthquakes, such as floods and tornados.

ACKNOWLEDGMENTS

The researchers express gratitude to the Muhammadiyah Higher Education Institution, particularly Research and Development Council, Muhammadiyah organization through Muhammadiyah's grant Batch V for their funding support in this research so that the activities can be worked as planned and promptly.

REFERENCES

- [1] Islahudin, I., Riadi, F., Rosdaniah, R., & Yuyun, Y. Y. Y. (2019). Rancang Bangun Sensor Tekanan Berbasis Koil Datar Untuk Mengukur Tekanan Hidrostatik Air Bendungan Rawan Banjir di Wilayah Lombok Nusa Tenggara Barat. *ORBITA: Jurnal Kajian, Inovasi dan Aplikasi Pendidikan Fisika*, 5(1): 1-4.

- [2] Ayub, S., Kosim, K., Gunada, I. W., & Verawati, I. N. S. P. (2020). Analisis Kesiapsiagaan Bencana Pada Siswa Dan Guru Di Sekolah Dasar Negeri 6 Mataram. *ORBITA: Jurnal Kajian, Inovasi dan Aplikasi Pendidikan Fisika*, 6(1): 129-134.
- [3] Indriasari, F. N. (2016). Pengaruh pelatihan siaga bencana gempa bumi terhadap kesiapsiagaan anak sekolah dasar dalam menghadapi bencana.
- [4] Emami, S. B. (2015). *Pengaruh penyuluhan kesiapsiagaan menghadapi bencana gempa bumi terhadap pengetahuan siswa di SD Muhammadiyah Trisigan Murtigading Sanden Bantul* (Doctoral dissertation, STIKES'Aisyiyah Yogyakarta).
- [5] Yustisia, N., APRILATUTINI, T., & UTAMA, T. A. (2019). Pengaruh simulasi menghadapi bencana gempa bumi terhadap kesiapsiagaan siswa SDN 86 kota Bengkulu. *Journal of Nursing and Public Health*, 7(2): 32-38.
- [6] Haryuni, S. (2018). Pengaruh Pelatihan Siaga Bencana Gempa Bumi Terhadap Kesiapsiagaan Anak Usia Sekolah Dasar Dalam Menghadapi Bencana Gempa Bumi Di “Yayasan Hidayatul Mubtadiin Kediri. *Jurnal Ilmu Kesehatan*, 6(2): 133-139.
- [7] Qaristy, H., Utariningsih, W., & Ikhsan, M. (2022). Gambaran Kesiapsiagaan Siswa SD di Desa Pusong dalam Menghadapi Bencana Tsunami. *COMSERVA Indonesian Journal of Community Services and Development*, 1(12): 1112-1119.
- [8] Hayudityas, B. (2020). Pentingnya penerapan pendidikan mitigasi bencana di Sekolah untuk mengetahui kesiapsiagaan peserta didik. *Jurnal Edukasi Nonformal*, 1(1): 94-102.
- [9] Widjanarko, M., & Minnafiah, U. (2018). Pengaruh pendidikan bencana pada perilaku kesiapsiagaan siswa. *Jurnal Ecopsy*, 5(1): 1-7.
- [10] Sugiyono. (2013). *Metode Penelitian Pendidikan Pendekatan Kuantitatif dan Kualitatif*. Bandung. ALFABETA.
- [11] Islahudin, I., & Nizar, M. (2017). Pengembangan Sensor Koil Datar 3-D untuk Deteksi Gempa Dini di Wilayah Lombok. *Jurnal Nasional Teknik Elektro dan Teknologi Informasi*, 6(1): 84-92.
- [12] Islahudin, I., Sabaryati, J., Zulkarnain, Z., & Soeharto, S. (2020). Design of Work Instruction (WI) Electronic Workbench-Assisted Electrical Measuring Devices to Improve the Internship Concept of Students in Basic Electronic II Course. *JIPF (Jurnal Ilmu Pendidikan Fisika)*, 5(2): 98-106.
- [13] Islahudin, I., & Soeharto, S. (2020). Improving Students' Conceptual Mastery on Digital Circuit Topic Using Electronics Workbench Software. *JIPF (Jurnal Ilmu Pendidikan Fisika)*, 5(1): 8-16.
- [14] Islahudin, I., Khaerani, S., & Zulkarnain, Z. (2018). Pemanfaatan Laboratorium Virtual Berbasis Ewb (Electronics Workbench) Terhadap Peningkatan Hasil Belajar Fisika Siswa IPA Kelas XII IPA Ma NW Darussalimin Sengkol, Batukliang Lombok Tengah Tahun Pelajaran 2018/2019. *ORBITA: Jurnal Kajian, Inovasi dan Aplikasi Pendidikan Fisika*, 4(2): 47-51.
- [15] Islahudin. (2017). *Buku Ajar Dasar-Dasar Elektronika Analog, Digital, dan Sensor*. Yogyakarta: Deepublish.
- [16] Fandanu, R., Lestari, W., & Suharto, S. (2021). Diversitas Pendidikan Multidimensional dalam Pertunjukan Kentongan Bambu Laras Banyumas Jawa Tengah. *Virtuoso: Jurnal Pengkajian dan Penciptaan Musik*, 4(1): 20-30.
- [17] Asiyah, S. N. (2017). *Implementasi Pendidikan Karakter melalui Kegiatan Ekstrakurikuler Seni Budaya Kentongan dan Tari di MI Negeri Watuagung Tambak Banyumas* (Doctoral dissertation, IAIN).
- [18] Utami, D. R. R. B., Sari, D. K., Wulandari, R., & Istiqomah, A. R. (2021). Kesiapsiagaan Bencana Banjir Masyarakat Dusun Kesongo. *Jurnal Ilmiah Kesehatan Keperawatan*, 17(1): 01-07.
- [19] Rosyida, F., & Adi, K. R. (2017). Studi eksplorasi pengetahuan dan sikap terhadap kesiapsiagaan bencana banjir di SD Pilanggede Kecamatan Balen Kabupaten Bojonegoro. *Jurnal Teori dan Praksis Pembelajaran IPS*, 2(1): 1-5.
- [20] Sountrang, Y. Y. (2013). Modal Sosial Dalam Kesiapsiagaan Masyarakat Menghadapi Bencana Gunung Ijen Di Desa Kali Gedang Kecamatan Sempol Kabupaten Bondowoso.
- [21] Alrafsanjani, H. (2020). *Analisis Program Kentongan Di Radio Republik Indonesia Programa 3 Dalam Praktik Jurnalisme Bencana* (Bachelor's thesis, Fakultas Ilmu Dakwah dan Ilmu Komunikasi Universitas Islam Negeri Syarif Hidayatullah Jakarta).
- [22] Simandalahi, T., Apriyeni, E., & Pardede, R. (2019). Pengaruh Pendidikan Kesehatan Terhadap

Utilizing Flat Coil-Based Vibration Sensor on A Bamboo Drum as Disaster Preparedness Media For Students
Islahudin, Haifaturrahmah, Muhammad Nizaar, Soeharto

Pengetahuan Siswa Tentang Kesiapsiagaan Bencana Gempa Bumi. *Jurnal Kesehatan Medika Sainika*, 10(1): 107-114.